



## NORMA DE FABRICACIÓN

UNE 21-159

## MATERIAL

Acero SAE 1010 ó SCH40

## ACABADO

Galvanizado en caliente ASTM A-153

## ESFUERZO MÍN. A ROTURA

28 Kg / mm<sup>2</sup>

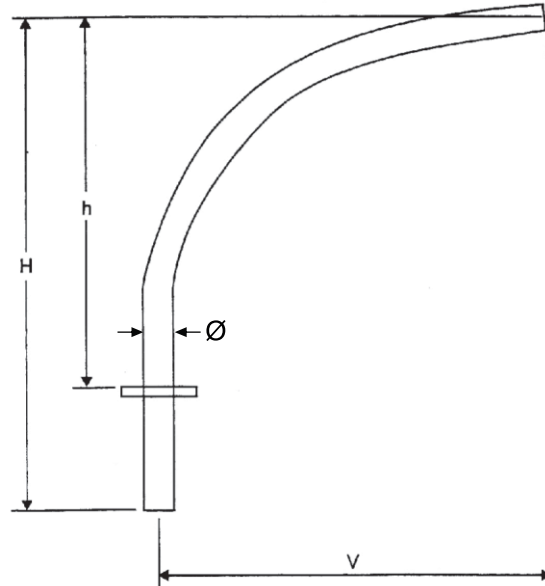

## CARACTERÍSTICAS TÉCNICAS

CÓDIGO	TIPO	DIAMETRO NOMINAL mm	DIAMETRO EXTERNO REAL Ø mm	V mm	H mm	h mm
062401	PS/1.5/1.9/1.5"	38	48	1500	2400	1900
062402	PS/3.2/3.0/1.5"	38	48	3200	3900	3400
062403	PS/3.4/2.3/2.0"	51	60	3400	2800	2300